

Spalding High School

Weekly Bulletin

16th November 2023

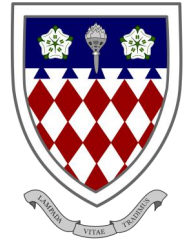

Gosh! Here we are in the middle of November already and starting to see information and publicity for some of the Christmas events that are just around the corner. This week's bulletin contains reminders about the Winter Concert (Wednesday 29th November) and I know, from hearing the rehearsals, that it is going to be fantastic and so I hope you have managed to buy tickets as I know the concert is already sold out.. Also this week, we have the Christmas Lunch menu which will be served on Wednesday 13th to Friday 15th December. The canteen are already getting ready for the big festive feast and we are all looking forward to the first "in-house" Christmas lunch. In answer to one of the main questions I have had this year (especially from younger students), – yes – if you want Christmas lunch each day and if your parents/carers are happy for you to have it every day, you can – although be prepared for needing an afternoon nap come Friday if you do...or is that just for people of my age?! The KS3 Christmas Disco tickets are also selling well and so get one of those too if you want one. My final reference to Christmas this week (I promise) is to remind Y7 that we are about to start work on the Y7 Christmas Tree competition and so make sure you are planning those house coloured, homemade decorations!

Tonight we are all looking forward to welcoming Year 11 from the High School and across the local area to the 16+ Information Evening; our Open Evening is for students looking to progress to the Sixth Form to study a range of subjects. It is vital that students make informed decisions about their next steps and gather all that they need in order to make those decisions and so we warmly invite everyone looking at 16+ progression routes to come and have a look around. I look forward to telling you all about it next week.

A final reminder that it is Children In Need non-uniform tomorrow – don't forget!

M K Anderson, Headmistress



Student of The Week

Please find below the latest 'Student of the Week' nominations. Nominations can be made by both teaching and support staff and can be subject related or community focused.

Form	Student	Staff	Reason
7J	Erica Mandache	Mr McAlinden	History
7N	Lacey Bourne	Mrs C Aurikko	Science
8N	Grace Maycroft	Mr Ganger	Mathematics
8N	Eydee Chilvers	Mrs Wilkins	Art
8P	Leila Petraite	Mrs Neal	Art
9C	Roxanne Fox	Mrs Lees	Library
9C	Karolina Gren	Mrs Jones	Latin
9J	Mahitha Suresh Babu	Miss Ashley	Mathematics
9J	Mahitha Suresh Babu	Miss Pettefar	English
9P	Darcey Greenwood	Mr Blackburn	German
9S	Dara Ajayi	Eva Spinks	Mathematics
10J	Kayley Bates	Miss White	Physics
10J	Katie Whittaker	Miss Bailey	German
10P	Annabelle Giles	Mrs Clay	French
10P	Shylini Bharaneedharan	Mrs Busfield	Community
11J	Briony Sweeting	Mrs Nowak	Mathematics
11N	Esme Piraino	Mrs T Waldron	Biology
11N	Lexi Goult	Mrs Busfield	Biology
11P	Sophie Wilson	Mrs Martin	Mathematics
6AF	Naya Valambhia	Mrs Martindale	Biology
6KM	Daisy Wilson	Mr Love	Law
6NG	Eloise Hudson	Mrs Cave	Religious Studies
6SC	Hannah Mukama	Mrs J Lord	English Literature
6TD	Gwennan Barker-Smith	Mrs Jones	Community

Celebrating The Individual In Year 9 - Lilah Teeuw, 9J

I come from a family of creative people. My Mum pursued a career in graphic design and is currently an executive creative director at a design agency. My Dad also studied art in college, and my Grandma is a respected local artist. Additionally, my Uncle is a talented portrait artist. It's safe to say that creativity runs in my blood.

I find inspiration in the most unlikely places. Whether it's an old book cover or a piece of modern art, I am always on the lookout for interesting things that can inspire me.

I like to explore a wide range of creative expressions. The creative industry is vast and constantly evolving, and being 'good at drawing' is not the only way to succeed. Ideas are the foundation of any piece of creative work, and the way you express those ideas is what makes a piece of work great.

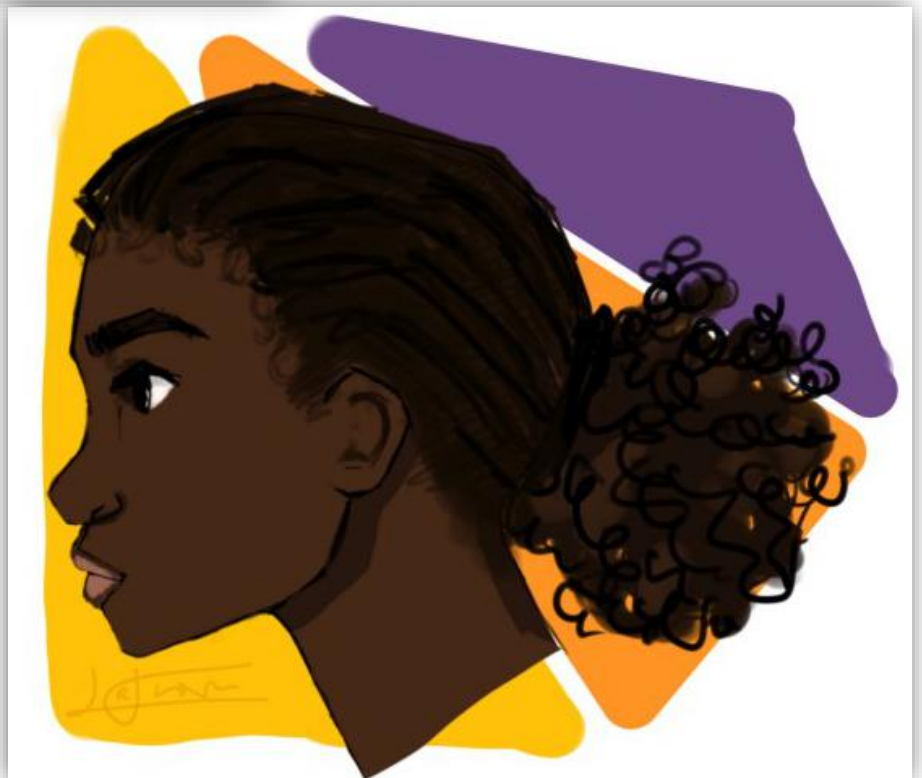
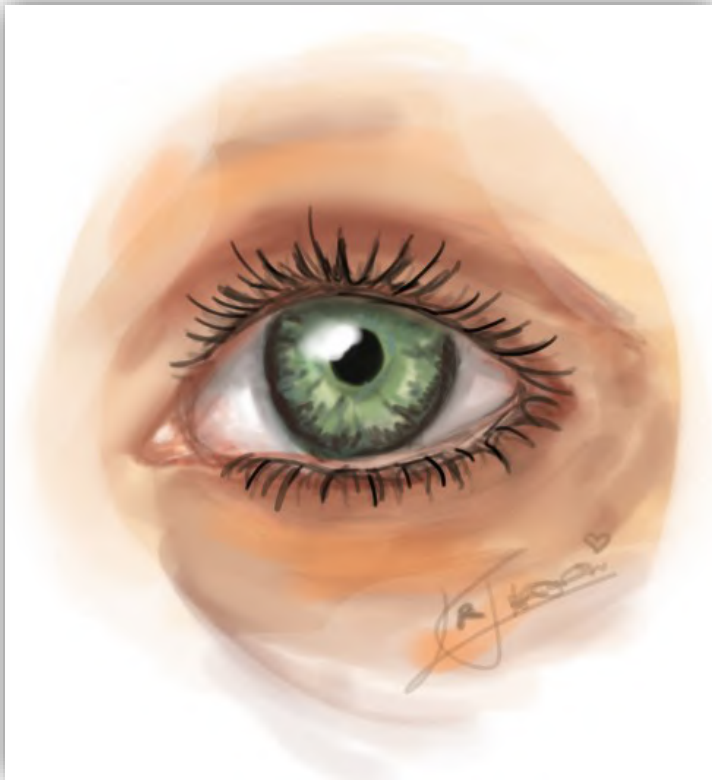

PE News

Year 7 Netball

Congratulations to the Y7 netball team, who won their second league game on Tuesday 14th November against The Deepings School. They won 9-0, and the match was played with great spirit; both teams learning a lot about the game of netball. A special congratulations to Lily, who was named Player of the Match by the opposition.

Miss Jones, PE department



PE News

Year 9 and Year 11 Netball

Last week, Y9 and Y11 played netball against The Deeping School. Both teams played extremely well and demonstrated excellent attacking play and skilful shooting which resulted in 30 goals in each game. Both teams defended with determination and confidence, creating turnover balls which lead to possession and goals. Well done to both teams for winning your games.



PE News

Year 9 Netball

On Sunday 11th November, the Year 9 netball team represented South Lincolnshire at the County Schools' Tournament. The team showed great spirit and played with a high level of skill and resilience. The team implemented newly learnt centre passes which surprised the opposition's defence and allowed SHS to retain possession. There was some fantastic defending in all games which resulted in numerous turnovers and penalties. When SHS were in possession, the attacking play was quick and effective, there was also some spectacular shooting from Izzy and Amiyah. Overall, the students finished fourth, losing out on the 'Plate' by three goals. They won three games, drew one and lost three. They should all be proud of their performance!

Miss Parker, PE Department



PE News

Year 7 and 8 Rugby

On Wednesday 8th November sixteen Year 7 and 8 students braved the elements and spent the day learning how to play rugby at Kesteven Rugby Club. In true rugby spirit, the rain added to the fun and made the ground softer to tackle and fantastic to mud slide!

Students spent the morning learning key skills needed for a game of rugby such as tackling, rucking and attacking. In the afternoon students were put into mixed teams with five other schools and played a tournament. Considering the vast majority of students had never held a rugby ball prior to the event, I am extremely proud to say they all went into each game with pure determination and courage.

I received a lot of positive feedback about the students at SHS from the coaches delivering the session, They complimented them on their impeccable behaviour, effort and skill level. One coach even said 'I honestly can't believe they have never played before!'

Enjoy the before and after photo of the students!

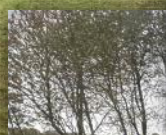

PHSCE News

Lincolnshire Police



Lincolnshire Police want to know and understand the level of trust and confidence the community have in them by asking one question **Taking everything into account, how good a job is Lincolnshire Police doing?**

It is really important that we understand this for different communities, and this will help inform the further work we want to do. This is why we are reaching out to young people in schools asking them to complete a quick and easy survey answering this question. It is very simple and should only take 1 minute to complete.

Thank you,

**Supt Patrick Coates
East Area Supt**

Web link: <https://forms.office.com/e/t5rvVGwkdy>

Let us know how we are doing.. (5)



Week 1 - Challenge #1 - Answer

Here is the answer to last week's Challenge the Parent question:

Did you get it right?

Working	Answer
$180 \div 9 \times 1:180 \div 9 \times 3:180 \div 9 \times 5$ $= 20:60:100$ Not enough cement (but enough sand and enough gravel) OR $1 \times 15:3 \times 15:5 \times 15$ $= 15:45:75$ $15 + 45 + 75 = 135$ (<180) Not enough cement (to make 180kg of concrete)	No + reason

Week 2 - Challenge #2

Jane has a carton of orange juice.
The carton is in the shape of a cuboid.

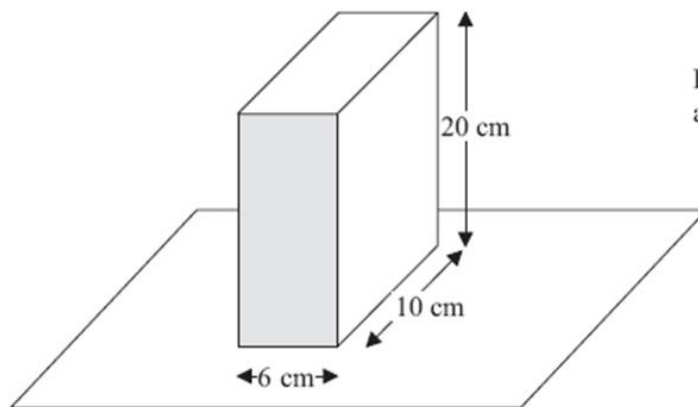

The depth of the orange juice in the carton is 8 cm.

Jane closes the carton.
Then she turns the carton over so that it stands on the shaded face.

Work out the depth, in cm, of the orange juice now.

English News

Christopher Tower Poetry Competition

The 24th Christopher Tower Poetry Competition will run from October 2023 to February 2024, with students between 16-18 years of age challenged to **write a poem on the theme 'Mirror.'** This is a prestigious competition for young poets, thirteen young people will scoop a total prize fund of more than £14,000 for writing a poem on a set theme.

About Tower Poetry | Christ Church, University of Oxford

Please click on the link for entry details:

[Tower Poetry Submission Manager - The Christopher Tower Poetry Competition 2024 \(submittable.com\)](https://www.submittable.com)

Mrs Lord, Head of English

Pastoral News

Keeping children safe online

Within our school community we all have a part to play in keeping children safe online. Over the coming weeks we will use the bulletin to share resources to support parents and carers in their role to keep their child safe. Please share and discuss the information at home. In addition, there are links to further support on the school website.

The first resource can be found on the next page. This poster will also be shared with students in school and displayed in form rooms.

Mrs Jarvis and Mrs Davies, Pastoral Department

Spalding High School Christmas Lunch

Tickets are now available for the Spalding High School student and staff Christmas Lunch on Wednesday 13th, Thursday 14th and Friday 15th December. For more details, please see the poster attached to this Bulletin.

What is the minimum age for account holders on these social media sites and apps?

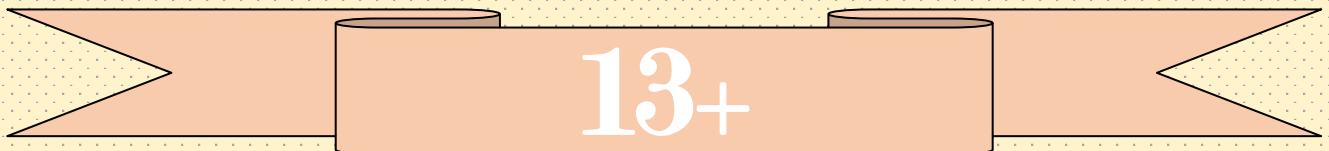

Facebook
Instagram
Snapchat
TikTok

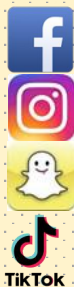

Twitter (known as 'X')
WhatsApp (16+ without PP)
Wink
BeReal



BE KIND ONLINE

Online abuse can have a severe impact on people's lives and can follow you wherever you go, whether you are the victim or the perpetrator.

KEEP POSTS POSITIVE

It may be tempting to post negative things about another person, but this is a form of bullying, think how you would feel to see a negative post about yourself. Don't comment on a negative post, understand the impact of your words/actions. It is very easy to detach from the consequences of our actions. Unkind comments DO have consequences and can add to someone's distress and feeling about themselves. Treat others the way you would like to be treated. Be respectful to yourself and those around you online.

STAY SAFE ONLINE

There are lots of fun and interesting things you can do on the internet and it can be a great way to stay in touch with friends.

But it's important to understand how to stay safe online.

Be RESPONSIBLE

Don't share personal details

Watch out for phishing and scams

Think about who you are talking to

Never give out your password

www.childline.org.uk/info-advice/bullying-abuse-safety/online-mobile-safety/staying-safe-online/

Sixth Form News

Charity Bingo

On Friday 10th November, the Prefect Team hosted their charity bingo to raise money for the ActionAid, donating all profits from the evening towards the education of girls in developing countries. We were pleased to see so many students, teachers and their families coming to support this cause! The evening included six games of bingo (with some expert number calling from Mrs Ray!) and a raffle with a variety of prizes to be won! The prefects were also selling drinks and snacks throughout the night to keep everyone well-sustained; some of the sixth form got rather competitive as the night went on! We managed to raise £475 to donate to ActionAid, so thank you to everyone who came to support us and helped with the evening! - **Misha Rajesh 6LM**



Sixth Form News

Remembrance Day

On Sunday 12th November, we attended the Remembrance Day Service in Spalding. We started in the procession towards Asycoughfee Hall to the War Memorial where the service started, behind Cadets, Guides and the Royal British Legion. The service featured a local veteran speaking the poem 'For the Fallen', as well as speeches by the District Council Leader and Sir John Hayes. We, along with Spalding Grammar and Spalding Academy, were invited to lay a wreath to remember the fallen; this was the most poignant part of the service for us as we were reminded of our privileged position thanks to the ultimate sacrifice of the soldiers. The ceremony ended with the Hymn 'Abide with me' and the Lord's Prayer. Overall this was a valuable experience and we appreciated the experience to share Remembrance Day with so many brave people in our community.



Jess Smith 6SC & Evie Booth 6JL

The UCAT, University Clinical Aptitude Test

This is a two hour multiple choice admissions test, taken in the summer between Year 12 and Year 13 by students planning to apply for medicine, it consists of five sections, Verbal Reasoning, Decision Making, Quantitative Reasoning, Abstract Reasoning and Situational Judgement. It tests your logical thinking skills, this is not a knowledge-based test! It can be taken within a three month window, between July and September, you can pick your own date and this can be moved if needed.



Our top tips:

- * Start preparing early. Online, you will find that it's suggested to begin preparation 6-8 weeks before your test date. However, we found that beginning to familiarise yourself with the test structure and skills required a few months beforehand can be a big help!
- * Timing is vital. The questions themselves aren't the challenge, it's the speed at which you have to do them. Keyboard shortcuts will be your friend!
- * Complete as many mock practices as you can. We used Medify and Medentry, but there are all sorts of resources out there

This is a challenging test, both to prepare for and sit. You might find yourself overwhelmed, but this is normal and it is so important to make time to do the things you love. It is a long journey, but have faith in yourself throughout the process and we know you can do it!

"Misha Rajesh scored within the top 3% of the UK this cycle, which is a huge achievement!" - Mrs Waldron

Please feel free to contact either of us if you have any questions regarding the UCAT or medicine applications in general.

Charlotte Ciuberkyte 6IW and Misha Rajesh 6LM

Environmental Committee

Thank you to everyone who has supported the ring pull competition, this project supports the purple community fund, aided by the Spalding Rotary Club'.

Finley Preen, 6SC



Careers Update

Higher and Degree Apprenticeships Listing

The Higher and Degree Apprenticeship Listing showcases hundreds of vacancies from a diverse mix of employers starting in 2023 and 2024. The variety of vacancies listed range from Engineer to Police Constable – there's something for everyone. Please note, the listing only contains a selection of current higher and degree apprenticeship vacancies. For the full range of live vacancies, please visit the government website, Find an Apprenticeship : <https://www.gov.uk/apply-apprenticeship>

Please see the current listing as an attachment.

Apprenticeship Accelerator Event

Rate My Apprenticeship is hosting a free online event on Thursday 30th November from 5.00-7.30pm for students and parents/carers to find out more about apprenticeships, where to look for them and how to apply. Please see the attachment for more information. Here is the link to register:

[RateMyApprenticeship Virtual Event](#)

Life as a Solicitor Apprentice at Dentons

Dentons is holding an insight webinar on 21st November 6.30-7.15pm for students in Years 10-13 and their parents/carers. Find out about the programme, applying and support on offer for apprentices.

Here is the registration link:

[Microsoft Virtual Events Powered by Teams](#)

Could students please let me know if they register to attend.

Saffery Apprenticeship Evening – 23rd November from 5pm

Please see the invitation below from Saffery and the flyer attached to this newsletter. This is a great event for any sixth form students interested in accountancy and finance.

We are pleased to invite your students to our upcoming Apprenticeship Evening at Saffery. This event is designed to provide students with an opportunity to learn more about the apprenticeship opportunities in accountancy and finance in the Peterborough area.

The event will take place on Thursday 23rd November from 5pm at our offices located at Westpoint, Peterborough Business Park, Lynch Wood, Peterborough PE2 6FZ. We will be providing information about our apprenticeship programs but also have guest speakers in the form of First Intuition (A local accountancy college), The One Group (recruitment agency) and ARU University.

We believe that this event will be of great value to your students who are interested in pursuing a career in accountancy and or tax.

We look forward to seeing your students at the Learn & Earn Event.

Creative Careers Week 13th to 17th November

Creative Careers Week is an initiative to inform students about different sectors, job roles, career pathways and more, across the thriving creative industries.

The creative industries include:

- Music, performing arts, like acting, and visual arts, like painting
- Crafts, such as weaving, furniture-making and jewellery-making
- Film, TV, animation, visual effects, video, radio and photography
- Video games, virtual reality, and extended reality
- Museums, galleries and heritage, such as stately homes and cathedrals
- Publishing and libraries
- Design, including product design, graphic design and fashion
- Architecture
- Advertising and marketing

Resources to use to find out more about the creative industries:

[Overview of the UK's creative arts sector | Prospects.ac.uk](#)

[Find your perfect role in the creative industries - Creative Careers \(discovercreative.careers\)](#)

Uncover Engineering – Year 10 Residential Programme

Please see the information below about a residential course (2nd-5th April) run by the University of Oxford:

Uncover is a residential programme that gives girls and Black African and Caribbean heritage students in year 10 the opportunity to explore maths and physics subjects in the context of Engineering studies, while offering a glimpse into university life.

The programme is run by Oxford University and students will stay in a college for 4 days. Days will be filled with engineering-focused activities and workshops organised by the Department of Engineering Science. In the evenings we have arranged recreational activities and social opportunities with other like-minded future engineers. You'll also find out about life at Oxford and living in a college (including a formal dinner!). On the final day, we hope that your parents will join us to learn more about studying engineering at a university like Oxford.

Successful applicants will be invited to participate in a follow-on programme in coming years, aiming to build the Uncover community.

Further details can be found here: **[Uncover Engineering - Year 10 Residential Programme \(ox.ac.uk\)](#)**

I am happy for students to give my contact details if they apply and let me know.

Medic Mentor Opportunities

For students in Years 10-12, Medic Mentor is once again offering support for the next cohorts of aspiring medical students with their free virtual live Get into Medicine UCAS conferences:

Saturday 25th November

Sunday 26th November

Students and parents can register for free at this link: <https://medicmentor.org/get-into-medicine-ucas-conference/>

These conferences offer tailored advice for applications to medicine, covering a range of crucial topics:

- Tactically choosing universities
- Personal statements
- UCAT
- Medical interview skills
- Medical Leadership Programmes
- Awards Programmes
- Extracurricular activities
- Work experience
- Building a CV
- Applying for scholarships

Both students and parents are encouraged to participate in these invaluable sessions.

Spaces are limited, so students should register as soon as they can using the link below:

Registration Link: <https://airtable.com/appgXnyzN5ZD9lwk6/shry7MZytt3MGPjvO>

Here's how the day will run:

9:30-10.00 Registration

10.00-11:00 Quick introduction to Medic Mentor, overview of the day, competition ratios, application timeline, Awards and Scholarships

11:00-11:15 Break

11.15-11.45 Introduction to the UCAS application form and entry requirements

11.45-12.15 Interactive CV building exercise and exclusive access to leadership, research, presentation, publication, prizes and scholarship opportunities

12.15-12.30 Top tips from a successful applicant (medical student)

12:30-12:45 Break

12.45-13.30 How to write the perfect personal statement

13.30-13.45 Break

13.45-14.10 Entrance exams - how to ace the UCAT

14.10-14.30 How to prepare for Medical School interviews

14.30-15.00 Top tips from a successful applicant (medical student) and next steps

Support:

As always, we can be contacted by email if parents/carers or students in any year group have any queries:

Dawn.bushell@spaldinghigh.lincs.sch.uk

Lucy.obrien@spaldinghigh.lincs.sch.uk

Mrs Bushell, Careers Leader



SPALDING FIRE STATION NEEDS YOU!

Spalding Fire Station is looking for people interested in becoming On Call Fire Fighters. The role is not full-time, therefore you can make yourself available to respond to incidents in and around your primary employment and family commitments. Some of our On Call Fire Fighters have an agreement with their employers to respond to emergency calls whilst at work, others make themselves available whilst their children are at school, some give cover whilst working from home and others manage full-time employment alongside their fire service commitment. Once trained, an On Call Fire Fighter will be issued with an alerter which will activate when you are required to respond to a 999 call.

All station personnel will come together one evening a week to complete 2.5 hours of training to maintain and develop their skills. You will work as a team using the latest equipment and life-saving techniques, to attend property fires, road traffic collisions, chemical spills, animal rescues, floods and many other incidents. The role is exciting, challenging and rewarding and we encourage people to apply from all walks of life. On Call Fire Fighters receive payment for being on call, completing training and attending incidents.

Due to the nature of the job, applicants must have a reasonable fitness level, be aged 18 or over and live or work within 5 minutes of Spalding Fire Station.

If you think being an On Call Fire Fighter might be for you there is lots of information on our website: www.lincolnshire.gov.uk/lfr or you can call our recruitment line for more information: 0800 3580 204. You are very welcome to pop down to the station on a **Monday** evening between **18:30 - 21:00** for an informal chat with the crew if you wish to find out more.

Spalding High School

Winter Concert

Wednesday
29th November 2023

7.30pm

Refreshments at 7.00pm

Tickets available online soon

